

 www.carlack.com.pl



KATALOG FRONTÓW LAKIEROWANYCH

 71 383 45 45

 biuro@carlack.com.pl

CARLACK
fronty meblowe

 ul. Leśna 6
56-321 Bukowice

CARLACK

fronty meblowe

- ◀ CARLACK to prywatne przedsiębiorstwo istniejące od 1999 roku.
- ◀ Specjalizujemy się w produkcji frontów oraz komponentów meblowych.
- ◀ Posiadamy własną mieszalnię farb i lakierów.
- ◀ Wieloletnie doświadczenie pracowników przy produkcji elementów meblowych zapewnia najwyższą jakość produktów.
- ◀ Nasze technologie są stale udoskonalane. Dążymy, aby nasze produkty były zgodne z obowiązującymi standardami.
- ◀ Nasza firma jest ciągle modernizowana tak, aby dostosowywać się do potrzeb i oczekiwań klientów.

Zapraszamy do współpracy!

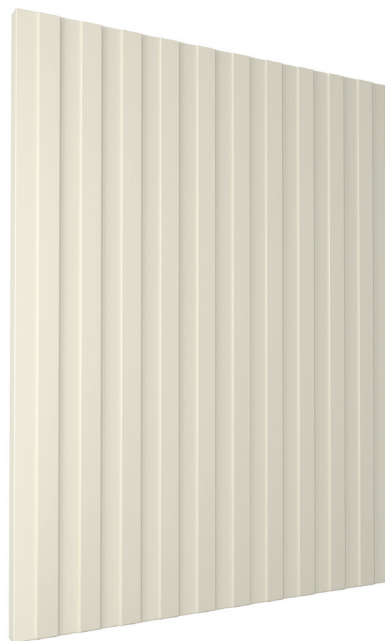

LAMELKA L-1

GŁĘBOKOŚĆ WYBRANIA - 3 mm

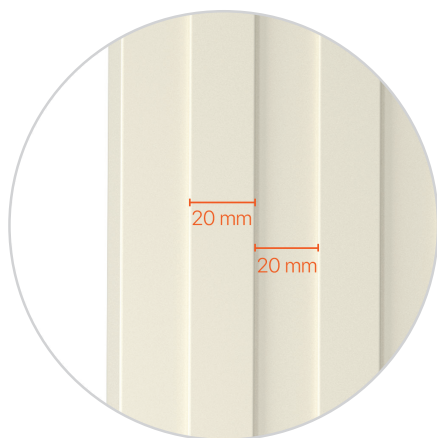

LAMELKA L-2

GŁĘBOKOŚĆ WYBRANIA - 3 mm

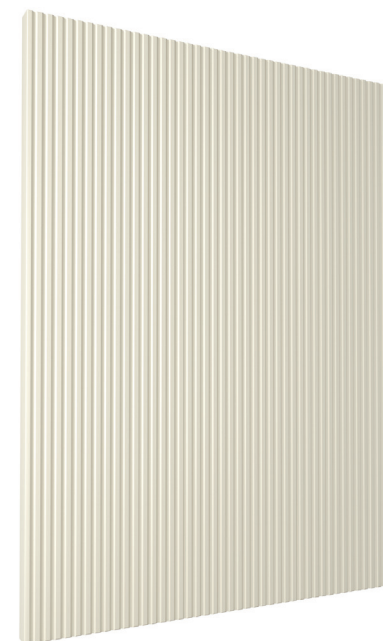
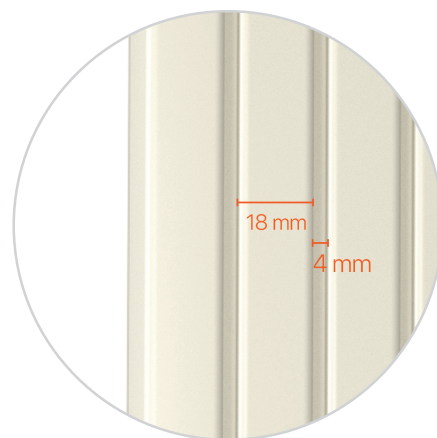

LAMELKA L-3

GŁĘBOKOŚĆ WYBRANIA - 2 mm

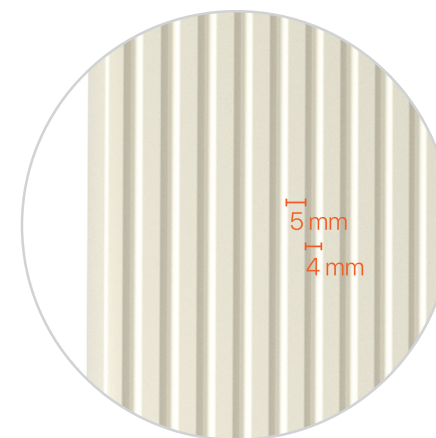



LAMELKA L-4

GŁĘBOKOŚĆ WYBRANIA - 3 mm

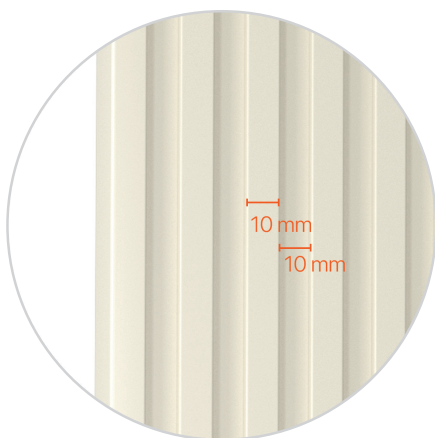

LAMELKA L-5

GŁĘBOKOŚĆ WYBRANIA - 6 mm
STANDARDOWA GRUBOŚĆ - 22 mm

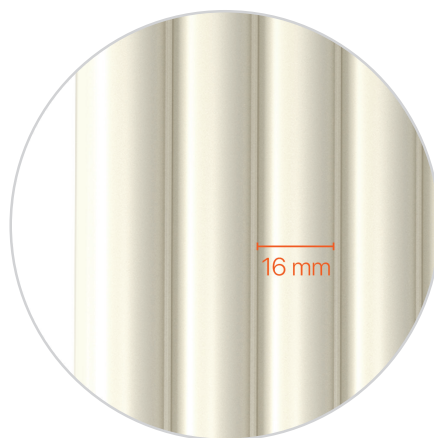

JODEŁKA

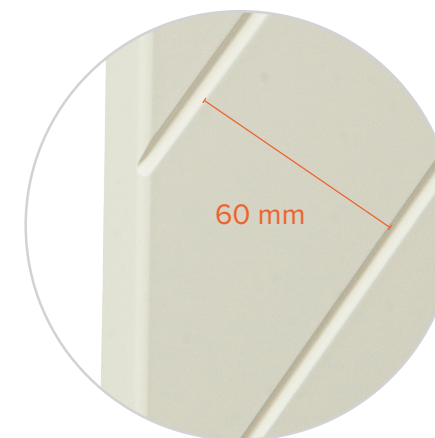

FRONTY
RAMOWE

MBS/R2

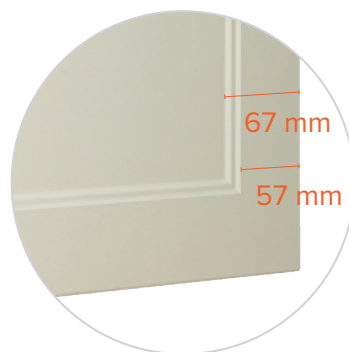

BARSAK/R2

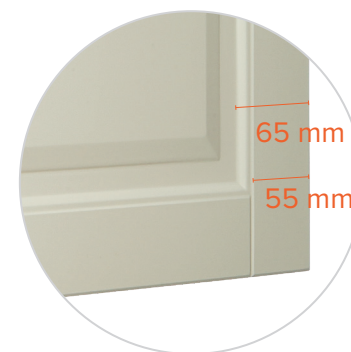

P/5/R2



PR/6/R2



PR/9/R2

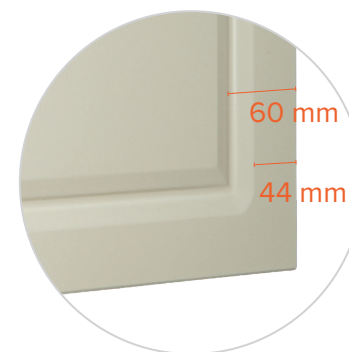

PR/10/R2

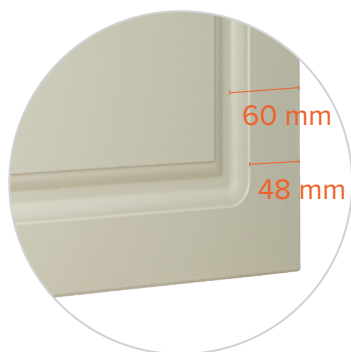

PR/11/R2



PR/20/R2

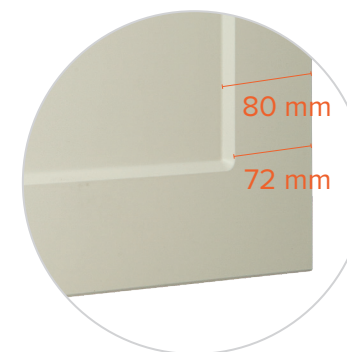

PR/21/R2

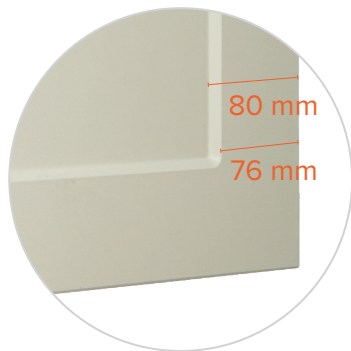

PR/33/R2

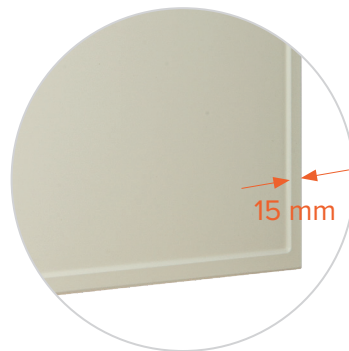

PR/50/R2

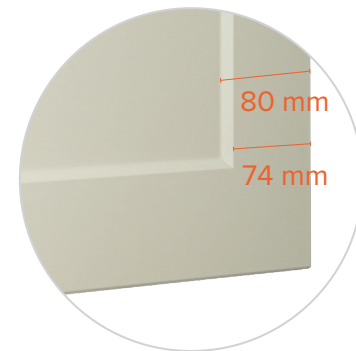

PR/51/R2

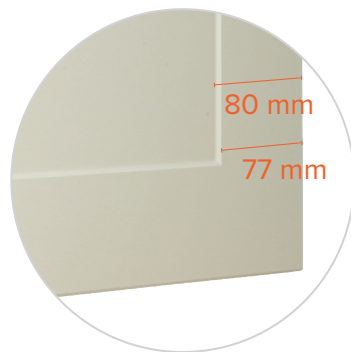

GLOBAL/R2

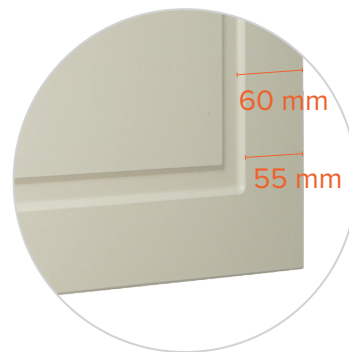

AVINA/R2

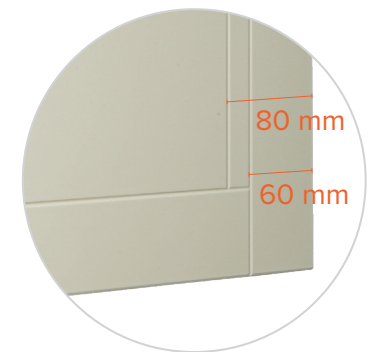

LOTUS/R2



MEFO/R2

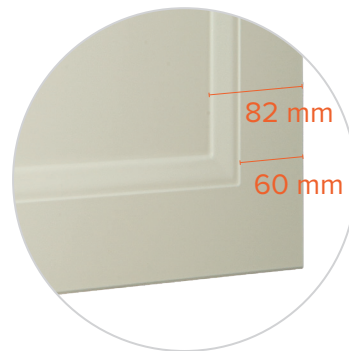

S1/RAJO/R2

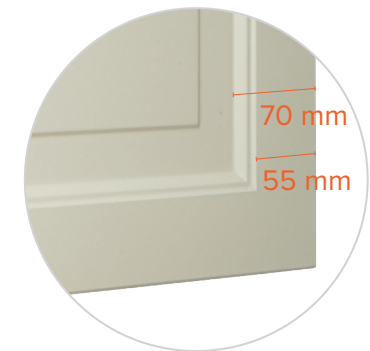

P/3/MSM



GRZEŚ/R2

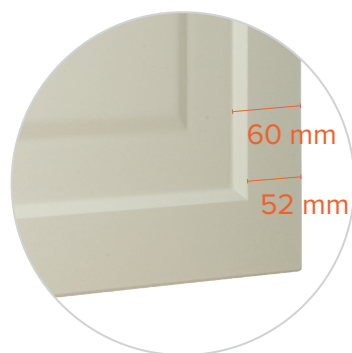

MEGAN/R2

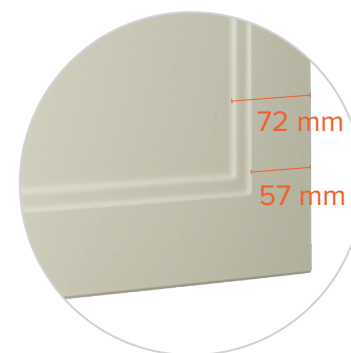

MARYSIA/R2

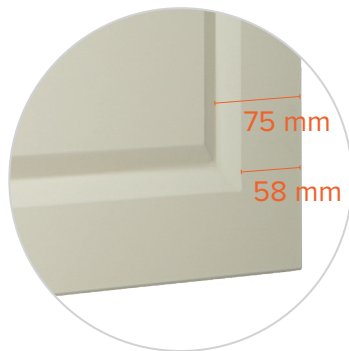

RAMONA/R2

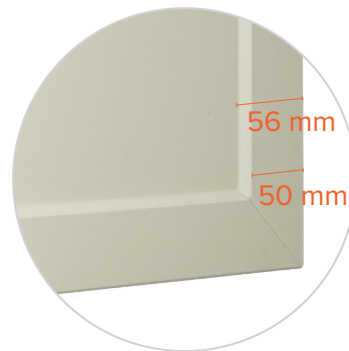
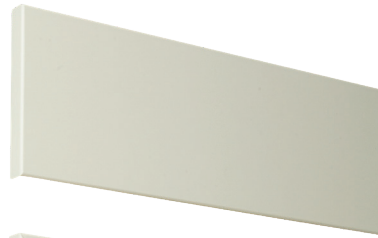

KEG/R2
STANDARDOWA GRUBOŚĆ: 22 mm

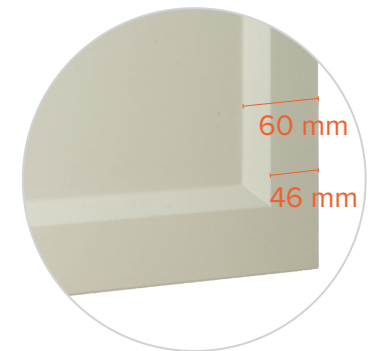

WITRYNY

WITRYNA W1



WITRYNA W2

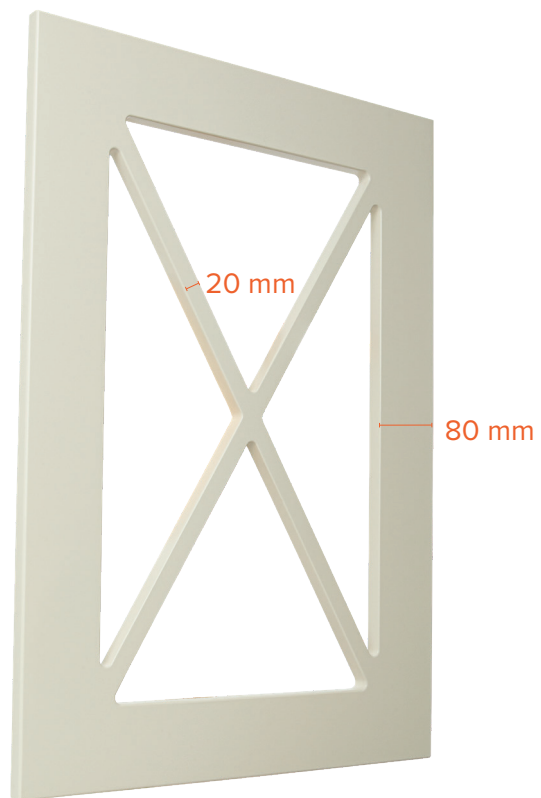

WITRYNA W3*

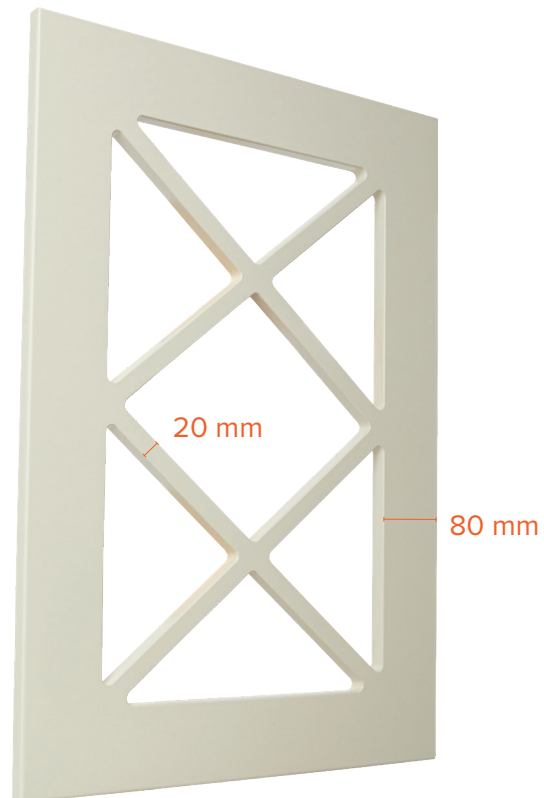

WITRYNA W4*

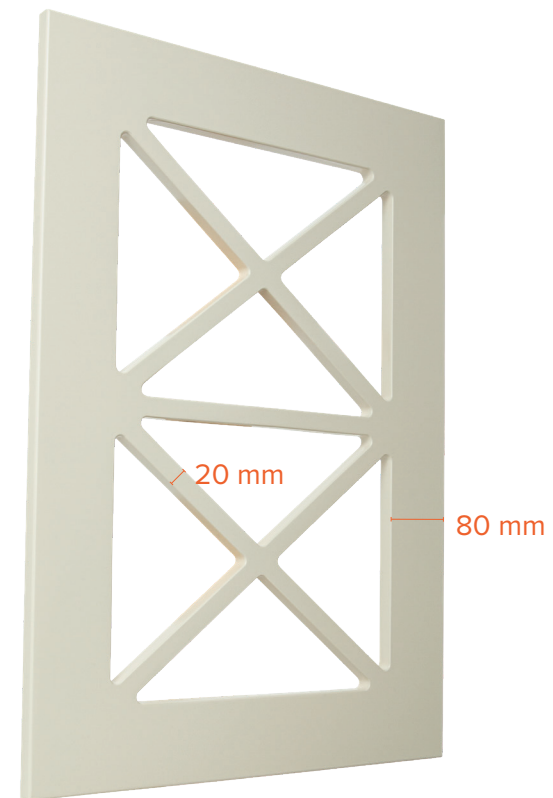

WITRYNA W5*

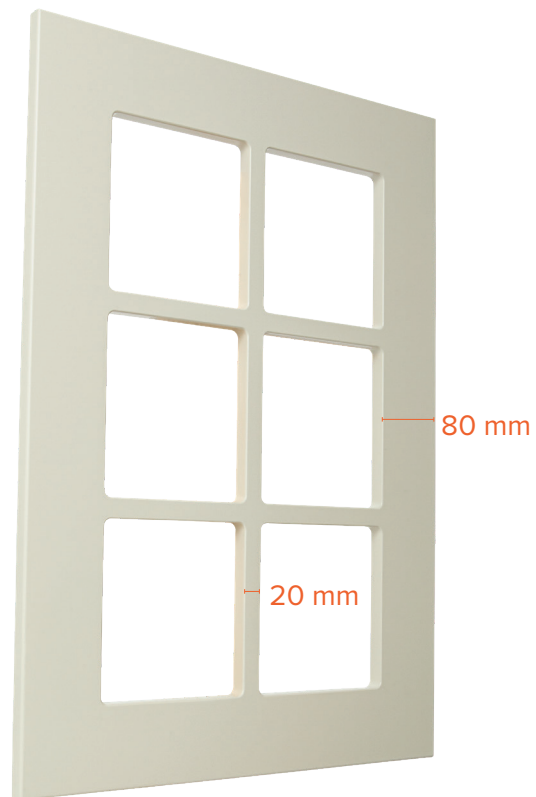

WITRYNA W6*



WITRYNA W7



*- zdjęcie poglądowe. Przy składaniu zamówienia należy podać ilość okienek.

UCHWYTY
FREZOWANE

UCHWYT „A”

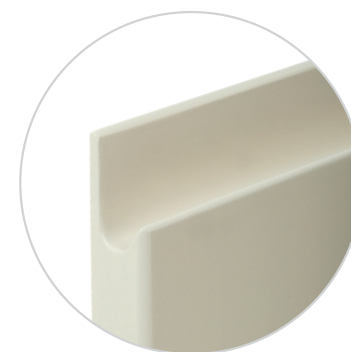

UCHWYT „B”

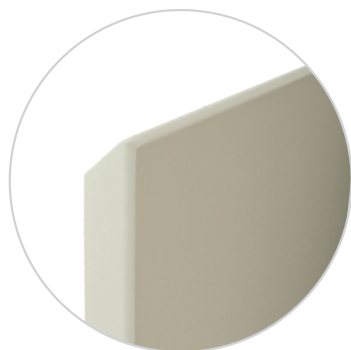

UCHWYT „C”



UCHWYT „E”

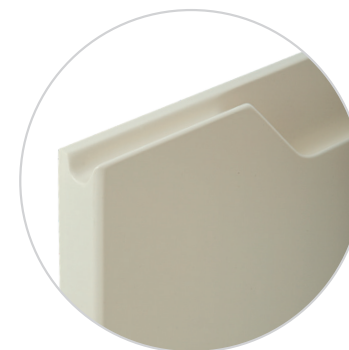

UCHWYT „F”

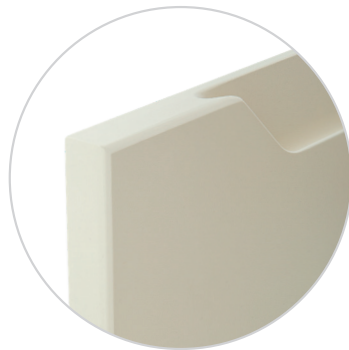

UCHWYT „UKW5”

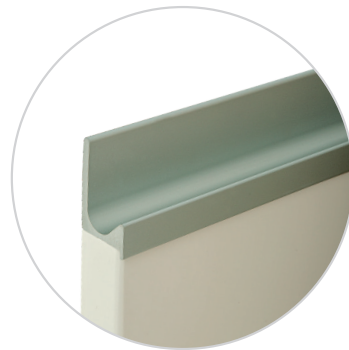

UCHWYT „UKW7”

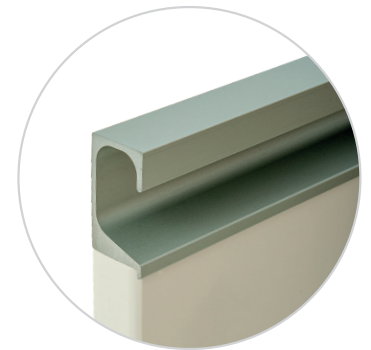

PILASTRY
LISTWY
WIEŃCZĄCE

PILASTER P1

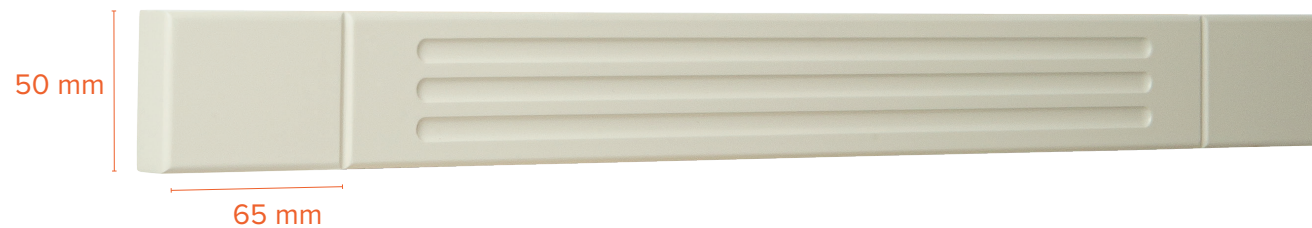

PILASTER P2



PILASTER P3



LISTWA LW13

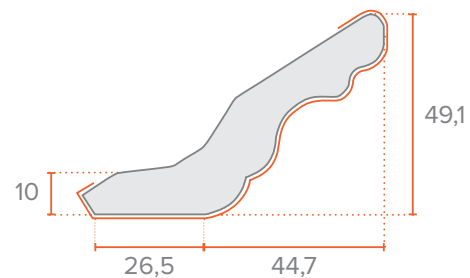
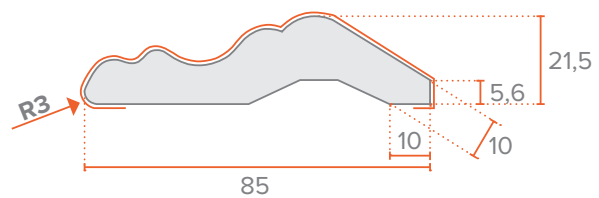

LISTWA LW16

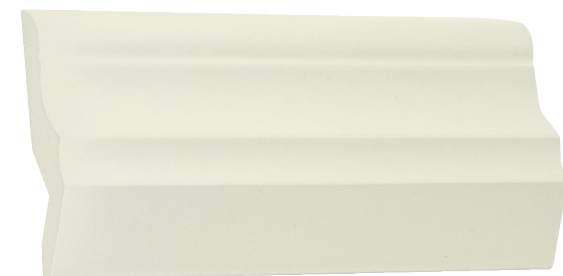
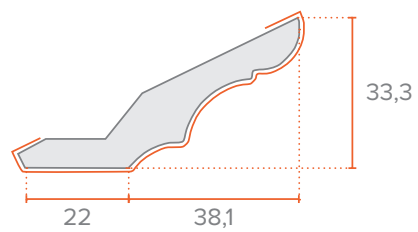
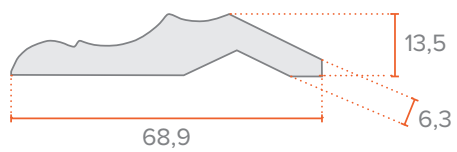

LISTWA LW25

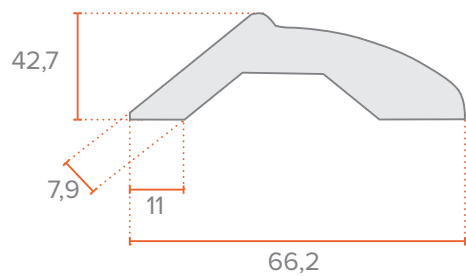

LISTWA LW27

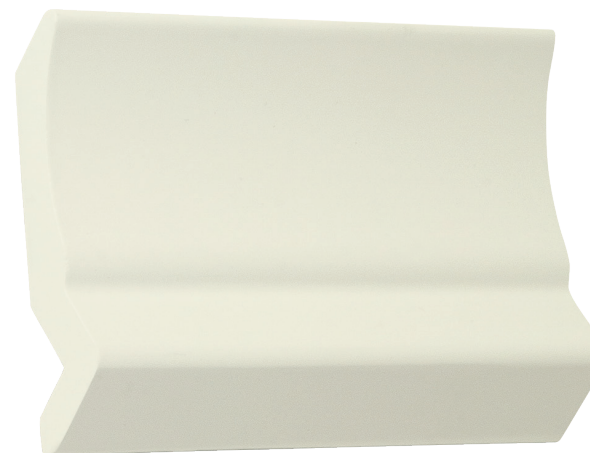
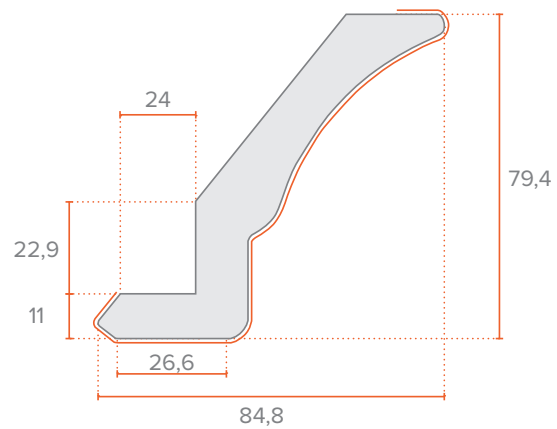
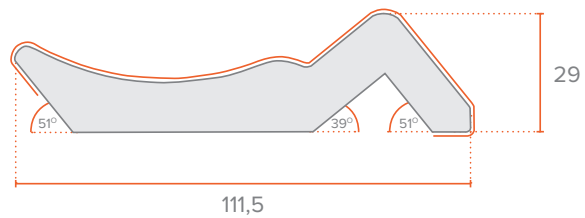

INFORMACJE TECHNICZNE

- ◀ Pracujemy na wzornikach - **RAL K7, NCS, ICA.**
- ◀ Standardowa grubość frontów wynosi **18 mm.**
- ◀ Dostępne grubości w MDF:
10 mm, 16 mm, 18 mm, 22 mm, 28 mm, 38 mm, 50 mm.
- ◀ Uchwyt występuje **w standardzie po szerokości.**
- ◀ Dostępne trzy wykończenia powłok: **połysk, mat, velvet.**
Brak określenia, skutkuje wykonaniem **w połysku.**
- ◀ Standardowa krawędź frontów gładkich i ramiakowych to **R2.**
Możliwość indywidualnego doboru frezowania.
Frezy obwiedniowe do wyboru: R1, R2, R5, R10, M, MS2, MS5, MSM.
- ◀ Dostępny **maksymalny wymiar** frontu, wykonanego przy użyciu maszyny CNC wynosi **2800x1200 mm.**
- ◀ Wszystkie zamówienia powinny być rozpisywane na naszym oryginalnym arkuszu zamówieniowym. Klienci, którzy nie stosują się do powyższego, muszą liczyć się z faktem, iż w przypadku błędnego przepisania zamówienia przez dział handlowy, ewentualna reklamacja nie będzie uwzględniona.
- ◀ Przy lakierowaniu lewej strony matem, niemożliwe jest wykonanie zaoblenia krawędzi.



Dział sprzedaży

tel./fax **71 383 45 45**

tel. kom. 600 599 044 joanna@carlack.com.pl

tel. kom. 664 768 869 agnieszka@carlack.com.pl

Dział reklamacji

tel. kom. 530 554 020 reklamacje@carlack.com.pl

Pełna oferta firmy znajduje się na **www.carlack.com.pl**



ul. Leśna 6, 56-321 Bukowice

Godziny otwarcia: Pn.-Pt. 7:00-15:00.

Zapraszamy!



NINIEJSZA INFORMACJA NIE STANOWI OFERTY HANDLOWEJ W ROZUMIENIU KC.
PRODUCENT ZASTRZEGA SOBIE PRAWO DO WPROWADZENIA ZMIAN BEZ UPRZEDNIEGO O NICH POINFORMOWANIA ZAINTERESOWANYCH STRON.

